

Twista Tradesman Installation Instructions - 500mm Tile

WARNING: you must be wearing a long sleeve shirt and safety gloves while performing any installation to prevent injury from all sharp edges ...and in case of the two collar halves detaching.

www.Twista.com.au

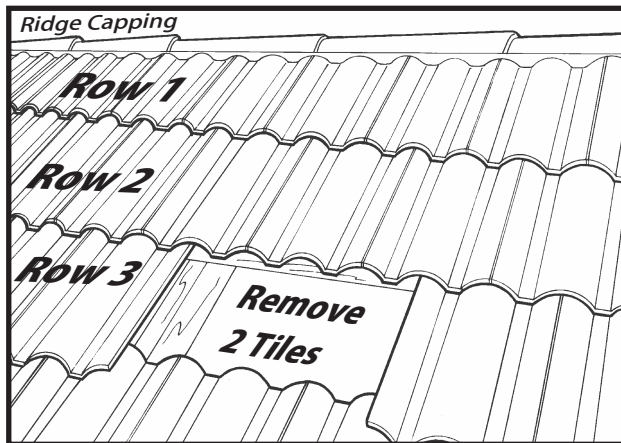

1

Select the desired location for your VENTILATOR. Count down to the 3rd row of tiles from the **ridge capping** and carefully remove 2 or 3 tiles (depending on tile size) to provide an opening equal or wider than the **outlet hole** in the **flashing panel**.

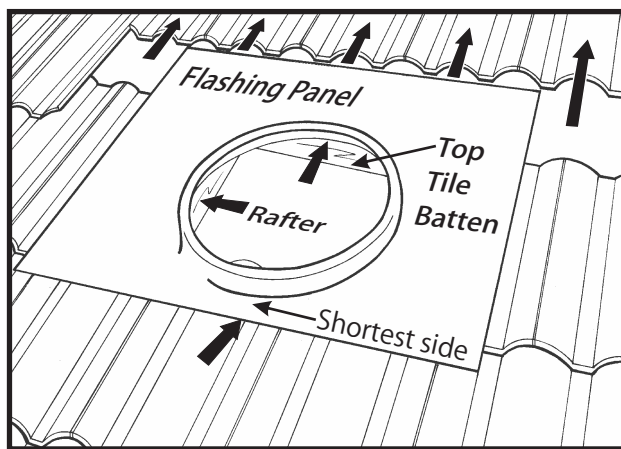

2

Slide the second row of tiles below the ridge upwards to clear the entire width of the **flashing panel**. Position the **flashing panel** over the roof opening ensuring that the **outlet hole** sits more or less between the rafters. Position the top edge of the **outlet hole** in line with the edge of the **top tile batten**. Make sure the **shortest side** of the **flashing panel** is facing down the roof slope.

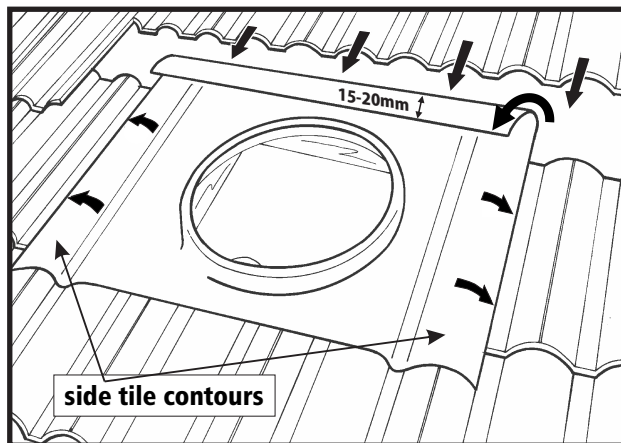

3

Bend down and form the two sides of the **flashing panel** to follow the **side tile contours**. Roll 40mm of the top edge up and over ensuring a return lip of **15-20mm** is gained. Reposition the **flashing panel** over the roof opening. While holding it in place, slide the row of tiles above back down as far as possible to hold the flashing in place. Please note that some specialty tiles (Terracotta and Swiss pattern for example) may require cutting to fit neatly ...most times they don't.

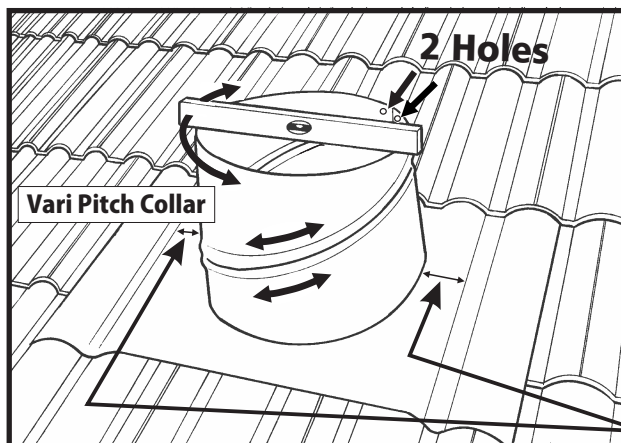

4

Place the **variable pitch collar** onto the **flashing panel**. Ensure that the end with the **2 holes** is at the top (see illustration). Slide the two halves of the collar against one another to vary the pitch angle. Adjust so that the top of the collar is sitting horizontally when viewed from all angles. **Keep a clearance gap on each side of collar for water runoff.**

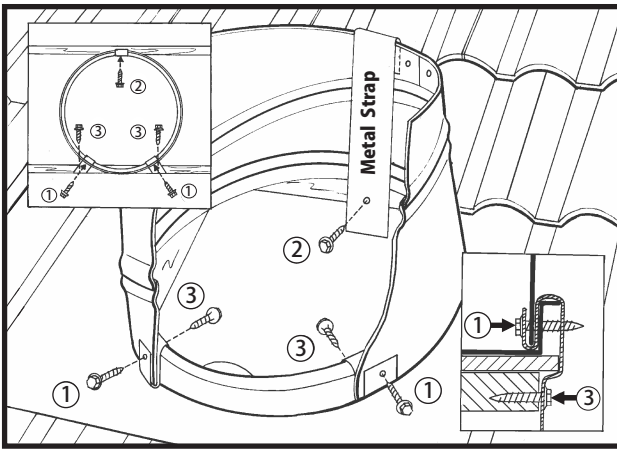

5

Secure the **flashing panel** and collar onto the roof by using the three metal straps and self-tapping screws supplied. Carefully bend and position the metal straps at approximately 12, 5, and 7 o'clock as shown. Screw the collar to the **flashing panel** through the front two straps (position 1). While pulling straps down firmly, screw each strap to roof timbers in positions 2 & 3 as shown.

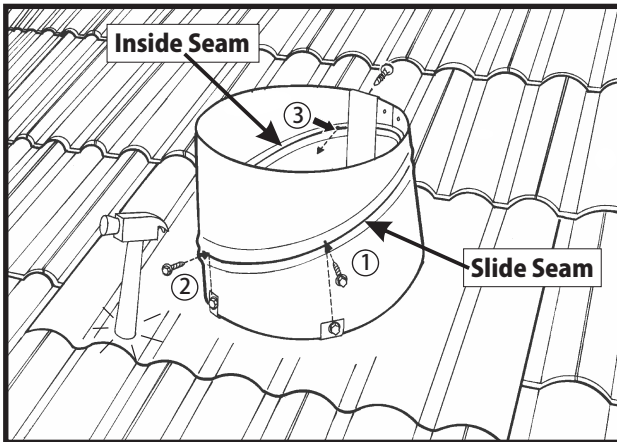

6

Using a hammer handle, gently form the bottom and side edges of the **flashing panel** to the tile contours. Ensure that there are no large gaps between the **flashing panel** and the tiles. Re-check the level of the collar and adjust if necessary. Screw three screws into the collar **variable pitch slide seam** (joint) directly above the two metal straps at the front (1 and 2) and slightly to the side of the rear strap (3). Ensure the 3 screws are gripping the 2 layers firmly together without over tightening. Note: for high wind areas silicone can be used on the **inside seam** to bond both layers of the metal collar ...remove oil film **before** silicone.

DO NOT secure any item with Pop Rivets

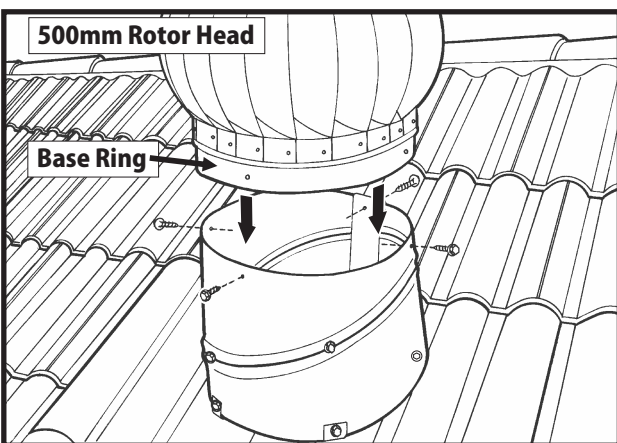

7

Place the rotor head onto the collar, aligning one of the four fixing points with the centre of the rear strap where it is folded over the top of the collar. Fix the rotor head in place using 4 self-tapping screws supplied. Drive each screw in once and then unscrew all the way out and then re-screw it again to ensure a good stress-free attachment. Note: **DO NOT** over-tighten these 4 screws, the screw heads must **GENTLY** touch the outside body of the **base ring**. It must not place any pressure onto the **base ring** ...otherwise the base ring may crack.

Please note: We recommend that all installers are experienced in the installation of roof ventilators and that they have a carpenters, roofers or builder's license and that they are professional tradespersons who will conform to the latest mandatory government body regulations for **Working with Heights and Safety**. The supplier and manufacturer do not take any responsibility for any installation work or consequential damage caused by persons or organisations other than their direct employees.

Standard Tile Installation

Moulded, Sealed and Secured!

www.Twista.com.au

1- Remove 2 Tiles, then mould the flashing over the tile contours.

2- Upturn top section of flashing to stop updraft, then slide flashing underneath the row of tiles above



4- Fit the round throat (neck/tube) to the flashing, then adjust it so it's level on all sides.

5- Fit the 3 straps and secure to tile battens.

6- Mount the 500mm Twista Rotary Head onto the throat to finish.



DO NOT secure any item with Pop Rivets

3- Slide down the row of tiles above so they cover over the flashing

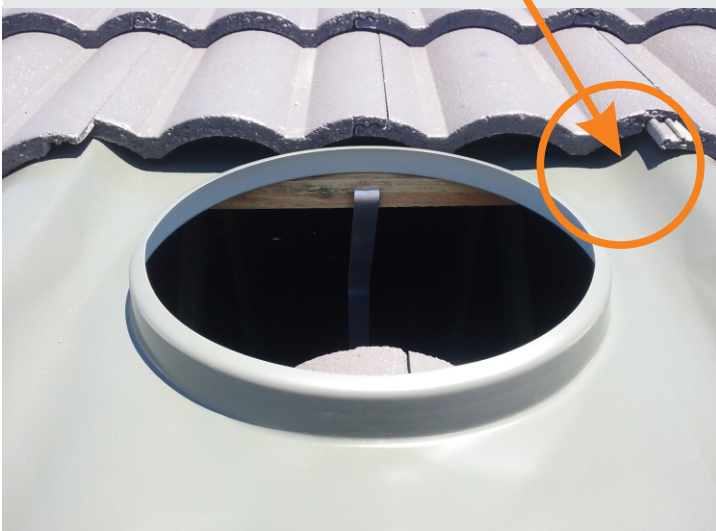

ALL Twista Vents Accurately Levelled with a Spirit Level



DO NOT secure any item with Pop Rivets

Flat Tile Installation

Press Fitted and Sealed!

www.Twista.com.au

1- Clean Tiles from Dirt and Grime, then place 2 Beads of Silicone on each side and 1 Bead at Bottom



DO NOT secure any item with Pop Rivets

2- Pre-mould Flashing & Press onto Silicone Firmly, then slide Top tiles down to cover over Flashing



3- Fit Throat, Level, then tie down with 3 Straps to timber battens.
4- Mount the 500mm Twista Rotary Head onto the throat to finish.



NOTE:

Flat tiles must be cleaned from dirt and grime before applying silicone



Metal Roof Installation*

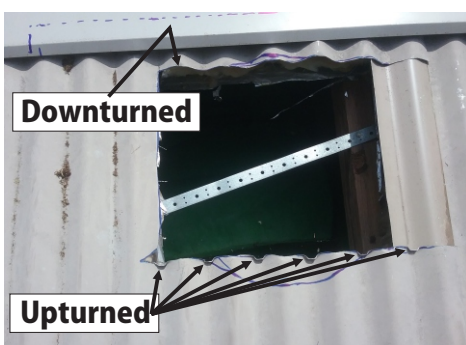
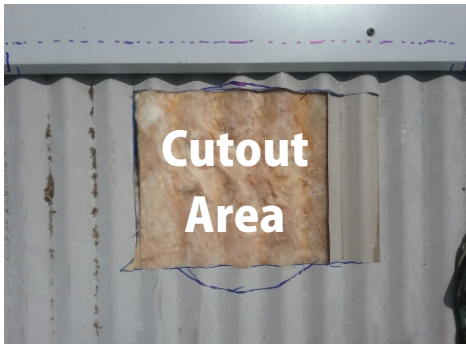
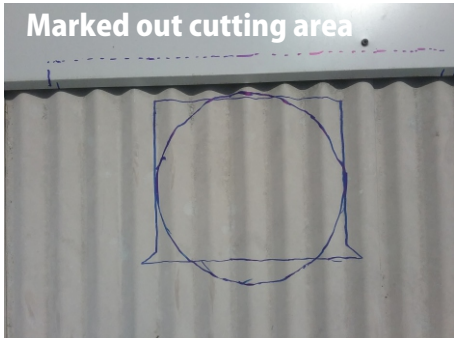
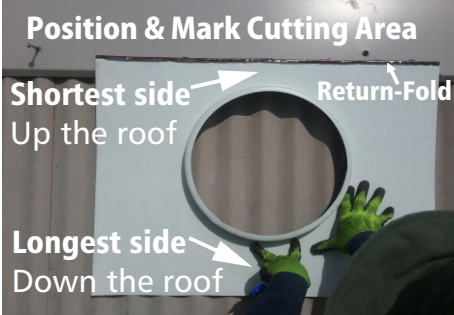

Industrial Vent Installation*

DO NOT secure any item
with Pop Rivets

